

# Clamp Ended Fittings

## BS / Imperial 45° Bends

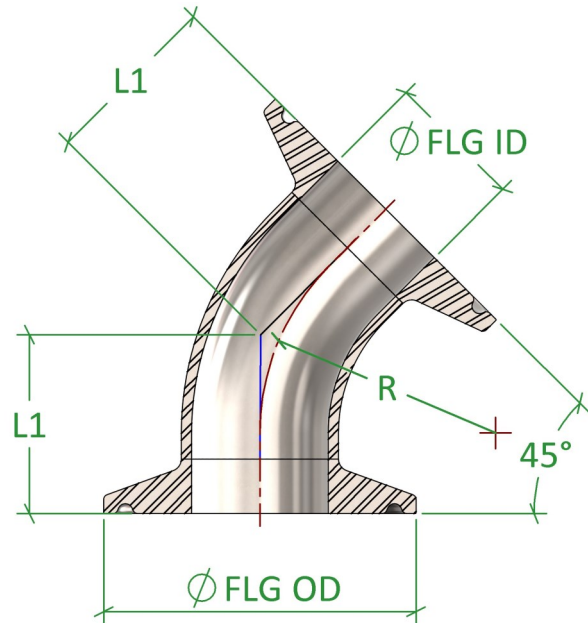

|                       |   |                             |   |
|-----------------------|---|-----------------------------|---|
| <b>Standard</b>       | BS4825-2 + BS4825-3   | <b>Certification</b>        | EN10204 3.1                                     |
| <b>Connections</b>    | TC Ferrule Ended  | <b>Associated Parts</b>     | Clamp Ended Tee's, 90 Deg ,TC Ferrules BS4825-3 |
| <b>Material</b>       | 316L Stainless Steel EN 1.4404  | <b>Associated Standards</b> | BS4825-3 / DIN32676-C                           |
| <b>Surface Finish</b> | Dull Polish, Welds Removed, (Approx. 1.0Ra µm )   | <b>Options</b>              | Other Sizes Available, Duplex Materials         |
| <b>Remarks</b>        | Standard BS4825-2 Fittings with BS4825-3 TC Ferrules Welded & Polished, No Welds Visible. |                             |   |

| Clamp Ended Fittings, BS/Imperial 45° Bends |             |             |  |  |        |         |             |
|---|-------------|-------------|--|--|--------|---------|-------------|
| Size (inch)                                 | FLG OD (mm) | FLG ID (mm) |  |  | R (mm) | L1 (mm) | Part Code   |
| 0.50"                                       | 25.40       | 9.40        |  |  | 19.00  | 19.80   | C45.BS.0050 |
| 0.75"                                       | 25.40       | 15.70       |  |  | 28.60  | 24.60   | C45.BS.0075 |
| 1.00"                                       | 50.50       | 22.10       |  |  | 38.10  | 28.50   | C45.BS.0100 |
| 1.50"                                       | 50.50       | 34.80       |  |  | 57.15  | 36.50   | C45.BS.0150 |
| 2.00"                                       | 64.00       | 47.50       |  |  | 76.20  | 44.50   | C45.BS.0200 |
| 2.50"                                       | 77.50       | 60.20       |  |  | 95.25  | 52.30   | C45.BS.0250 |
| 3.00"                                       | 91.00       | 72.90       |  |  | 114.30 | 60.30   | C45.BS.0300 |
| 4.00"                                       | 119.00      | 97.38       |  |  | 152.40 | 79.10   | C45.BS.0400 |

Published Data Is Given in Good Faith. We Reserve the Right To, Without Warning Change the Dimensions When Not In Conflict With The Published Standard

**Flowsource Process Fittings Ltd**

Unit 4 Marrtree Business Park, Cedar Road, Sowerby, Thirsk, North Yorkshire, YO7 3FF, United Kingdom  
 [T] 01535 274 316 - [e] sales@flowsourcepf.com - [w] www.flowsourcepf.com

**FLWSOURCE**  
**PROCESS FITTINGS**